

# **VAN GAS** TECHNOLOGIES™

## **INSTALLATION, OPERATION AND MAINTENANCE INSTRUCTIONS**

### **PIPE LINE DEHYDRATOR FOR NATURAL GAS PLD 8-2.8 thru PLD 36-2.8**



## **WARNING**

**DO NOT REMOVE, REPAIR OR REPLACE ANY ITEM ON THIS VESSEL WHILE IT IS UNDER PRESSURE.**

**DO NOT OPERATE IF THERE IS A LEAK IN VESSEL. IMMEDIATELY TAKE VESSEL OUT OF SERVICE AND CALL YOUR CERTIFYING AUTHORITY. IF THERE IS A LEAK, DEPRESSURIZE VESSEL, INSPECT, REPAIR AND OR REPLACE AS NECESSARY.**

**DO NOT OPERATE ABOVE MAXIMUM WORKING PRESSURE (MWP) AND OR ABOVE MAXIMUM OPERATING TEMPERATURE (DEGREES °F).**

**DO NOT WELD OR GRIND VESSEL. IT WILL NOT BE SAFE TO OPERATE.**

**DO NOT OPERATE IF THE VESSEL HAS BEEN DAMAGED BY FIRE. TAKE OUT OF SERVICE IMMEDIATELY AND NOTIFY YOUR CERTIFYING AUTHORITY.**

**ANY DAMAGE TO VESSEL CAN MAKE IT UNSAFE. INSPECT OUTSIDE AND INSIDE OF VESSEL REGULARLY FOR CORROSION OR ANY DAMAGE (I.E., DENTS, GOUGES OR BULGES). IF DAMAGED, TAKE OUT OF SERVICE IMMEDIATELY. CALL YOUR CERTIFYING AUTHORITY.**

# 1.0 OPERATION

A Pipeline Dehydrator removes the water vapor (humidity) present in the gas stream. The process cleans and dries the gas as it flows through a vessel which is filled with a special drying agent (desiccant). The dehydrator operates automatically. There are no moving parts and no external source of power is required.

"Wet" natural gas enters the lower portion of the dryer where liquid water and solid particles are separated by gravity and fall to the bottom of the vessel. The gas moves upward through the prebed and drying bed of Van Gas desiccant tablets. The tablets attract and absorb moisture from the gas as it flows through the desiccant bed. The tablets dissolve gradually as they absorb the moisture and the liquid falls to the bottom of the vessel. The liquid run off in the prebed creates an extended surface area capable of removing additional moisture from the gas. This conserves the absorbent desiccant tablets. The "dry" natural gas flows through the dryer outlet.

The solution of dissolved desiccant and water that falls into the claim area at the bottom of the vessel must be drained regularly to prevent the vessel from flooding. An automatic drain valve can be installed to prevent the vessel from flooding.

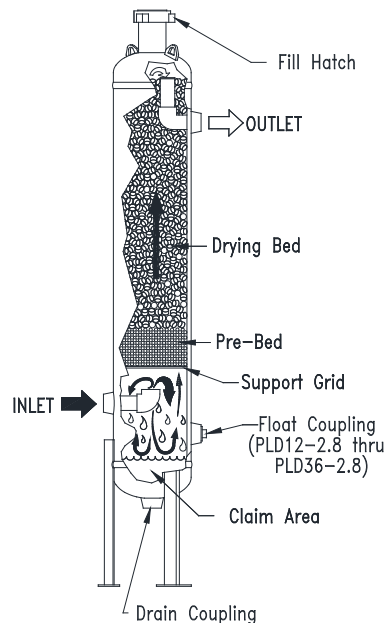

# 2.0 INSTALLATION

## 2.1 LOCATION

The ability of a dehydrator to dry natural gas is dependent on the correct location of the unit. Temperature and pressure are the keys to selecting the proper location.

**IMPORTANT**

**ALWAYS PROCESS THE GAS THROUGH THE DEHYDRATOR AT THE LOWEST TEMPERATURE AND THE HIGHEST PRESSURE.**

**INLET GAS TEMPERATURE:** Lower inlet gas temperatures will result in a lower moisture content at the outlet of the dehydrator. Locate the dehydrator at the point where temperature is the lowest.

**CAUTION**

**The gas temperature should not exceed:  
100°F for GASDRY PRIME  
80°F for GASDRY PEAK  
100°F for GASDRY MAX**

### MAXIMUM CAPACITIES - MSCFD

1,000 STANDARD CUBIC FEET PER DAY

MODEL NO.	PART NO.	MAXIMUM WORKING PRESSURE	50 PSIG	100 PSIG	150 PSIG	175 PSIG	200 PSIG	225 PSIG	250 PSIG	280 PSIG
PLD 8-2.8	80-1397	280 PSIG	42	75	108	124	141	157	173	193
PLD 12-2.8	80-1399	280 PSIG	79	141	202	233	263	294	325	362
PLD 16-2.8	80-1401	280 PSIG	125	221	317	365	413	462	510	567
PLD 20-2.8	80-1403	280 PSIG	192	341	489	563	638	712	786	875
PLD 24-2.8	80-1405	280 PSIG	280	497	714	822	930	1038	1147	1277
PLD 30-2.8	80-1468	280 PSIG	447	793	1139	1312	1485	1658	1831	2038
PLD 36-2.8	80-1407	280 PSIG	672	1191	1711	1970	2230	2490	2749	3061

**AFTERCOOLING:** If the gas being processed has been compressed mechanically, an aftercooler, finned tubing or extended run of piping will usually be necessary to reduce the inlet gas temperature to the dehydrator.

**OPERATING PRESSURE:** More gas can be processed through the dehydrator at higher pressures. Locate the dehydrator at the highest practical pressure, but do not exceed the maximum rated working pressure of the dehydrator. Refer to the capacity chart located below.

**CAPACITY:** The chart below indicates the maximum flow rate through the dehydrator for a 24 HOUR period. To calculate the capacity for a rate per minute just multiply the **MSCFD RATE (from chart ) by 0.6944** example:

A PLD 12-2.8 operating at 50 PSIG has a maximum MSCFD rate of 79. To figure the SCFM multiply 79 MSCFD x 0.6944 which equals 54.86SCFM

**NOTE:** This is the **MAX** instantaneous flow that can be processed through the dehydrator without deterioration of the drying performance.

## 2.2 PIPING AND ANCILLARY EQUIPMENT

### IMPORTANT

**COMPLY WITH ALL FEDERAL, STATE, AND LOCAL REGULATIONS CONCERNING INSTALLATION OF NATURAL GAS SYSTEMS.**

**COMPLIANCE TO AND KNOWLEDGE OF ALL REGULATIONS IS THE RESPONSIBILITY OF THE INSTALLER.**

Make sure that the temperature of gas is not over the maximum for the desiccant being used. If gas temperature is too high, cool it prior to the dehydrator.

Mount the dehydrator on a level surface capable of supporting the weight of the vessel, such as a cement pad or a skid.

**Install a pressure relief valve in the up-stream piping (relief valve not furnished). A relief valve must be installed to conform with the ASME Boiler and Pressure Vessel Codes, Section VIII, Division 1 UG-125, Paragraph (1) and OSHA standards. Also comply with all applicable Federal, State, and Local codes.**

## 2.3 INLET AND OUTLET PIPING

Two shut-off valves should be installed (not furnished with dehydrator)-one at dryer inlet and another at dryer outlet. See Figure 2-A Recommended Installation.

Connect the inlet and outlet piping as shown in Figure 2-A.

### NOTE

Inlet and outlet shut-off valves will make start-up and addition of desiccant easier.

## 2.4 AFTERFILTER

Van Gas "GF" Series Filters can be installed downstream of the dehydrator to remove particulate contamination from the natural gas. Contact Van Gas for details.

## 2.5 DRAIN VALVE

Install a drain valve (not furnished with dehydrator) in the drain coupling at the bottom of the tower (except on PLD8-2.8). A float/auto drain valve system is available. Contact Van Gas for details.

**FIGURE 2-A RECOMMENDED INSTALLATION**

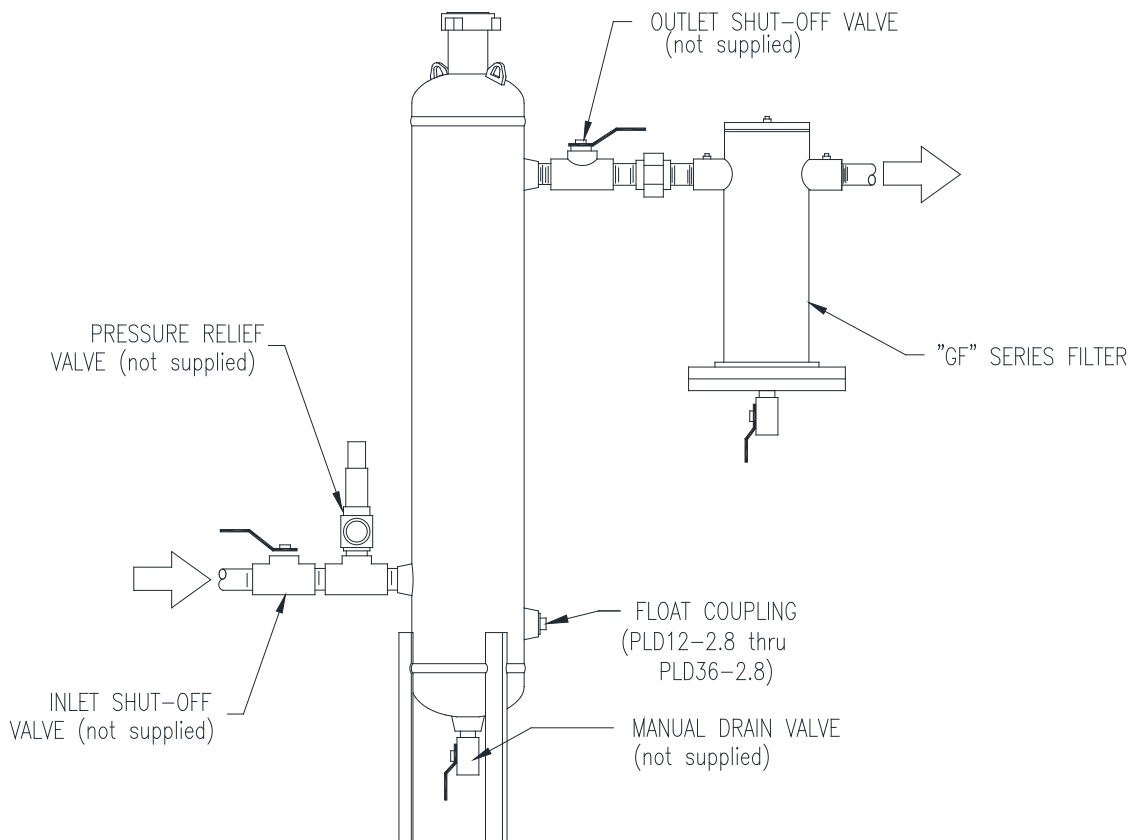

## 2.6 INSTALLING DESICCANT

### IMPORTANT

**DEPRESSURIZE DEHYDRATOR COMPLETELY BEFORE ATTEMPTING TO REMOVE FILL COVER.**

Open fill cover and add the proper amount of pre-bed material and desiccant to fill the dehydrator to the MAXIMUM LEVEL; then level off the top off the bed.  
(Reference SECTION 4.3 for desiccant installation instructions)  
**USE VAN GAS ABSORBENT DESICCANT ONLY!**

Close fill cover. Make sure that the inlet and outlet shut-off valves, and manual drain valve are closed.

**FIGURE 2-B DIMENSIONS**

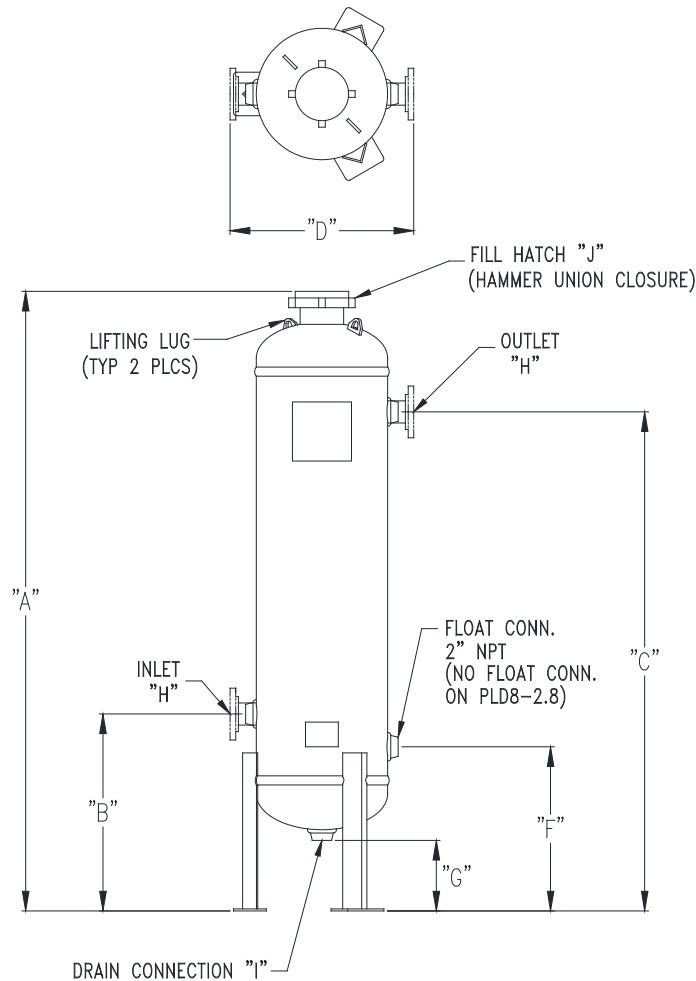

**DRYER DIMENSIONS-INCHES**

MODEL	DRYER DIMENSIONS-INCHES									
	A Overall Height	B Inlet Height	C Outlet Height	D In to Out Width	E Outside Dia.	F Float Height	G Drain Height	H Inlet /Outlet	I Drain	J Hammer Union
PLD 8-2.8	47-1/4"	13"	36"	13-1/8"	8-5/8"	N/A	2-7/16"	2" NPT	1" NPT	4"
PLD 12-2.8	73-13/16"	30"	58"	18"	12-3/4"	25"	14"	2" NPT	2" NPT	4"
PLD 16-2.8	74-1/8"	30"	58"	21-1/4"	16"	25"	13-5/8"	2" NPT	2" NPT	4"
PLD 20-2.8	76-5/8"	30"	58"	23"	20"	25"	11-5/8"	2" NPT	2" NPT	6"
PLD 24-2.8	74"	25-3/8"	52-7/8"	36"	24"	20-3/8"	6-1/8"	3" RF FLG 150#	2" NPT	6"
PLD 30-2.8	80-3/16"	30"	57-1/2"	42"	30"	25"	9-1/4"	3" RF FLG 150#	2" NPT	6"
PLD 36-2.8	81-3/16"	29-5/16"	56-13/16"	48-3/4"	36-3/4"	24-5/16"	6-7/8"	3" RF FLG 150#	2" NPT	6"

## 3.0 OPERATION

### 3.1 START-UP

Close dehydrator drain valve. See Figure 2-A Recommended Installation.

**SLOWLY** pressurize by opening the inlet shutoff valve (if installed).

Open the outlet shutoff valve (if installed) slowly to place dehydrator on stream.

**CAUTION**  
Make sure that the dehydrator is not subjected to sudden flow surges. Always open valves slowly to permit a gradual equalization of pressure between the dehydrator and the gas supply lines.

Use a solution of soapy water to check all pipe and fitting connections made during installation for leaks. If any leaks are present, immediately depressurize the system and remedy the problem before continuing operation.

### 3.2 SHUTDOWN

Before shutdown, use the manual drain valve to remove any liquid that has accumulated in the sump area of the vessel.

Close dryer inlet and outlet shutoff valves (if installed). Open drain valve to depressurize the vessel.

## 4.0 MAINTENANCE

### 4.1 MAINTENANCE

**WARNING**  
IF DRYER IS NOT DRAINED REGULARLY, FLOODING WILL OCCUR AND ACCUMULATED LIQUID MAY ENTER SYSTEM AND DAMAGE DOWNSTREAM EQUIPMENT.

Remove the fill cover.

Using the chart in Figure 4-A, determine the proper quantity of prebed.

Place the prebed into the dehydrator first. Level off the prebed.

Again using the chart in Figure 4-A determine the correct quantity and type of desiccant required to fill the dehydrator.

### 4.2 INSPECT DESSICCANT BED LEVEL

Check bed level monthly until the actual usage rate is determined.

During the drying process, the desiccant tablets dissolve slowly. More tablets must be added to the supply when the top of the bed drops to the MINIMUM LEVEL. The consumption rate is dependent upon several factors, such as inlet temperature and flow. In Section 4.5, DESICCANT CONSUMPTION, are several charts showing desiccant consumption rates. Use the charts to determine an approximate usage rate for your application.

Slowly pour the desiccant into the dehydrator. Level off the desiccant bed. The desiccant level should NOT be higher than the OUTLET screen.

Replace the fill cover.

#### NOTE

Use VAN GAS desiccants only. Filling dryer with any other material will void the warranty.

#### WARNING

**WHEN HATCH COVER IS REMOVED TO ADD DESICCANT, ALWAYS CHECK O-RING FOR SIGNS OF WEAR.**

**CHECK COVER FOR RUST, CORROSION OR DAMAGE; REPLACE AS NEEDED.**

**SEE SECTION 6 FOR REPLACEMENT PARTS.**

### 4.3 ADDITION OF DESICCANT

Close dryer inlet and outlet shut-off valves (if installed). Open drain valve and allow dryer to depressurize completely.

**WARNING**  
COMPLETELY DEPRESSURIZE DRYER BEFORE ATTEMPTING TO REMOVE FILL COVER.

Close the drain valve.

Slowly open the inlet shut-off valve (if installed) to pressurize the dehydrator.

Open the outlet shut-off valve (if installed) and place the dehydrator on stream.

**FIGURE 4-A BED LEVEL DETAIL**

DRYER DIMENSIONS-INCHES				
MODEL	A Dim. To Grid	B Dim. To Pre-Bed	C Dim. To MIN LEVEL	D Dim. To MAX LEVEL
PLD 8-2.8	29-1/2"	23-1/2"	15-1/2"	12-1/4"
PLD 12-2.8	36-1/2"	30-1/2"	14-1/2"	7-1/2"
PLD 16-2.8	37-1/8"	31-1/8"	15-1/8"	7-3/8"
PLD 20-2.8	39-3/8"	33-3/8"	17-3/8"	9-3/8"
PLD 24-2.8	40-3/8"	34-3/8"	18-3/8"	10-3/8"
PLD 30-2.8	41-7/8"	35-7/8"	19-7/8"	11-7/8"
PLD 36-2.8	43-5/8"	37-5/8"	21-5/8"	13-5/8"

MODEL	PRE-BED CERAMIC BEAD	DRYING GASDRY PRIME	DRYING GASDRY PEAK	DRYING GASDRY MAX
PLD 8-2.8	17 LBS	25 LBS	19 LBS	21 LBS
PLD 12-2.8	38 LBS	115 LBS	88 LBS	96 LBS
PLD 16-2.8	59 LBS	187 LBS	143 LBS	156 LBS
PLD 20-2.8	91 LBS	291 LBS	222 LBS	243 LBS
PLD 24-2.8	133 LBS	425 LBS	324 LBS	354 LBS
PLD 30-2.8	212 LBS	678 LBS	518 LBS	565 LBS
PLD 36-2.8	318 LBS	1018 LBS	778 LBS	848 LBS

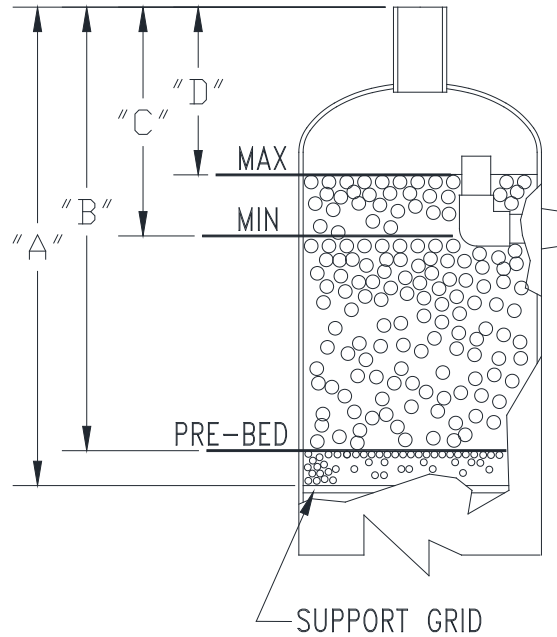

#### 4.4 BED LEVEL GUIDE

The level of the desiccant bed should be maintained as close to the MAXIMUM level as possible. The bed level should not be allowed to fall below the MINIMUM level. Dehydrator performance will be effected. Reference Figure 4-A for levels and quantities.

With the fill port cover removed, use a measuring stick to determine the distance from the top of the fill opening to the top of the desiccant bed. Reference Figure 4-A. Add desiccant as required to bring desiccant bed to maximum level.

**CAUTION**

**Never fill the vessel above the MAXIMUM LEVEL. Filling the vessel above the MAXIMUM level may effect the performance of the dehydrator.**

The desiccant bed level should be checked regularly. Section 4.4 DESICCANT CONSUMPTION will help you estimate the amount of desiccant that the dehydrator should use based on operating conditions.

#### 4.5 DESICCANT CONSUMPTION

Consumption rate based on average conditions. Actual conditions can vary.

##### 4.5-A GASDRY PRIME DESICCANT

This general purpose tablet is recommended for installations where inlet gas temperature is 100°F or lower. Depending on the pressure and temperature, GasDry Prime can provide a residual moisture content below 19 lbs/mmscf.

Chart 1 shows the level of dryness that GasDry Prime will provide at different conditions.

Chart 2 shows an approximate consumption rate for GasDry Prime at several conditions. Use the charts for guidelines to calculate the approximate consumption rate of the desiccant.

**CHART 1**  
**MOISTURE CONTENT OF GAS (LBS. H2O/MMSCF)**  
**AFTER DEHYDRATOR WITH GASDRY PRIME**

INLET TEMP	50 PSIG	100 PSIG	150 PSIG	175 PSIG	200 PSIG	250 PSIG	280 PSIG
100°F	391.8	224.7	159	139.2	124.0	102.1	92.6
95°F	336.5	193.1	136.7	119.7	106.6	87.9	79.8
90°F	288.9	165.9	117.6	103.0	91.7	75.7	68.7
85°F	246.5	141.6	100.4	87.9	78.4	64.7	58.7
80°F	210.2	120.8	85.7	75.1	67.0	55.3	50.2
75°F	178.1	102.5	72.8	63.8	56.9	47.0	42.7
70°F	150.3	86.6	61.5	53.9	48.2	39.8	36.2
65°F	126.9	73.2	52.0	45.7	40.8	33.8	30.7
60°F	106.9	61.7	43.9	38.6	34.4	28.5	26.0
55°F	89.0	51.4	36.7	32.2	28.8	23.9	21.7
50°F	74.4	43.0	30.7	27.0	24.1	20.0	18.2

**NOTE**  
**MMSCF is 1,000,000 STANDARD CUBIC FEET**

**CHART 2**  
**GASDRY PRIME CONSUMPTION RATE**  
**(LBS./MMSCF)**

INLET TEMP	50 PSIG	100 PSIG	150 PSIG	175 PSIG	200 PSIG	250 PSIG	280 PSIG
100°F	71.2	40.9	28.9	25.3	22.5	18.6	16.8
95°F	61.2	35.1	24.9	21.8	19.4	16.0	14.5
90°F	52.5	30.2	21.4	18.7	16.7	13.8	12.5
85°F	44.8	25.8	18.3	16.0	14.3	11.8	10.7
80°F	38.2	22.0	15.6	13.7	12.2	10.1	9.1
75°F	32.4	18.6	13.2	11.6	10.4	8.6	7.8
70°F	27.3	15.7	11.2	9.8	8.8	7.2	6.6
65°F	23.1	13.3	9.5	8.3	7.4	6.1	5.6
60°F	19.4	11.2	8.0	7.0	6.3	5.2	4.7
55°F	16.2	9.4	6.7	5.9	5.2	4.3	4.0
50°F	13.5	7.8	5.6	4.9	4.4	3.6	3.3

**4.5-B GASDRY PEAK DESICCANT**

The general purpose tablet is recommended for installations where inlet gas temperature is 80°F or lower. Depending on the pressure and temperature, GasDry Peak can provide a residual moisture content below 10 lbs/MMSCF.

Chart 3 shows the level of dryness that GasDry Peak provides at different conditions.

Chart 4 shows an approximate consumption rate for GasDry Peak at several conditions. Use the charts for guidelines to calculate the approximate consumption rate of the desiccant.

**CHART 3**  
**MOISTURE CONTENT OF GAS (LBS. H2O/MMSCF)**  
**AFTER DEHYDRATOR WITH GASDRY PEAK**

INLET TEMP	50 PSIG	100 PSIG	150 PSIG	175 PSIG	200 PSIG	250 PSIG	280 PSIG
80°F	126.1	72.5	51.4	45.1	40.2	33.2	30.1
75°F	106.9	61.5	43.7	38.3	34.2	28.2	25.6
70°F	90.2	51.9	36.9	32.4	28.9	23.9	21.7
65°F	76.1	43.9	31.2	27.4	24.5	20.3	18.4
60°F	64.1	37.0	26.3	23.1	20.7	17.1	15.6
55°F	53.4	30.9	22.0	19.3	17.3	14.3	13.0
50°F	44.6	25.8	18.4	16.2	14.5	12.0	10.9
45°F	37.0	21.5	15.3	13.5	12.0	10.0	9.1

**CHART 4**  
**GASDRY PEAK CONSUMPTION RATE (LBS./MMSCF)**

INLET TEMP	50 PSIG	100 PSIG	150 PSIG	175 PSIG	200 PSIG	250 PSIG	280 PSIG
80°F	116.4	66.9	47.5	41.6	37.1	30.6	27.8
75°F	98.6	56.7	40.3	35.3	31.5	26.0	23.7
70°F	83.2	47.9	34.1	29.9	26.7	22.0	20.0
65°F	70.3	40.5	28.8	25.3	22.6	18.7	17.0
60°F	59.2	34.1	24.3	21.3	19.1	15.8	14.4
55°F	49.3	28.5	20.3	17.8	15.9	13.2	12.0
50°F	41.2	23.8	17.0	14.9	13.3	11.1	10.1
45°F	34.2	19.8	14.1	12.4	11.1	9.2	8.4

**4.5-B GASDRY MAX DESICCANT**

Where extremely dry gas is required or where operating pressure is low, GasDry Max tablets provide a lower residual moisture content.

Chart 5 shows the level of dryness that GasDry Max will provide at different conditions.

Chart 6 shows an approximate consumption rate for GasDry Max at several conditions. Use the charts for guidelines to calculate the approximate consumption rate of the desiccant.

**CHART 5**  
**MOISTURE CONTENT OF GAS (LBS.H2O/MMSCF)**  
**AFTER DEHYDRATOR WITH GASDRY MAX**

INLET TEMP	50 PSIG	100 PSIG	150 PSIG	175 PSIG	200 PSIG	250 PSIG	280 PSIG
100°F	92.6	53.1	37.6	32.9	29.3	24.1	21.9
95°F	79.5	45.6	32.3	28.3	25.2	20.8	18.9
90°F	68.3	39.2	27.8	24.3	21.7	17.9	16.2
85°F	58.3	33.5	23.7	20.8	18.5	15.3	13.9
80°F	49.7	28.6	20.3	17.8	15.8	13.1	11.9
75°F	42.1	24.2	17.2	15.1	13.5	11.1	10.1
70°F	35.5	20.5	14.5	12.8	11.4	9.4	8.6
65°F	30.0	17.3	12.3	10.8	9.6	8.0	7.3
60°F	25.3	14.6	10.4	9.1	8.1	6.7	6.1
55°F	21.0	12.2	8.7	7.6	6.8	5.6	5.1
50°F	17.6	10.2	7.3	6.4	5.7	4.7	4.3
45°F	14.6	8.5	6.0	5.3	4.7	3.9	3.6
40°F	12.1	7.0	5.0	4.4	3.9	3.3	3.0

**CHART 6**  
**GASDRY MAX CONSUMPTION RATE (LBS./MMSCF)**

INLET TEMP	50 PSIG	100 PSIG	150 PSIG	175 PSIG	200 PSIG	250 PSIG	280 PSIG
100°F	206.6	118.5	83.8	73.4	65.4	53.9	48.8
95°F	177.4	101.8	72.1	63.1	56.2	46.4	42.1
90°F	152.3	87.5	62.0	54.3	48.4	39.9	36.2
85°F	130.0	74.7	53.0	46.4	41.4	34.1	31.0
80°F	110.8	63.7	45.2	39.6	35.3	29.2	26.5
75°F	93.9	54.0	38.4	33.6	30.0	24.8	22.5
70°F	79.3	45.6	32.5	28.4	25.4	21.0	19.1
65°F	66.9	38.6	27.4	24.1	21.5	17.8	16.2
60°F	56.3	32.5	23.1	20.3	18.2	15.1	13.7
55°F	47.0	27.1	19.3	17.0	15.2	12.6	11.5
50°F	39.2	22.7	16.2	14.2	12.7	10.6	9.6
45°F	32.5	18.9	13.5	11.8	10.6	8.8	8.0
40°F	26.9	15.6	11.1	9.8	8.8	7.3	6.7

**NOTE**  
**MMSCF is 1,000,000 STANDARD CUBIC FEET**

## 5.0 TROUBLESHOOTING CHECK LIST

If liquid water is detected downstream or if desiccant consumption seems excessively high, the most likely causes are as follows:

Problem	Possible Cause
Liquid downstream	The frequency of draining is not adequate.
High inlet temperature	Check inlet Temperature. Conditions may have changed. Determine the cause. If gas is compressed mechanically, check compressor aftercooler.
Low desiccant level	Check bed level to make sure that desiccant tablet level has not dropped below minimum level.
Incorrect flow and/or pressure	Check flow through dehydrator, refer to chart on page 2. Check inlet pressure.
Contaminated Desiccant bed	Inspect condition of desiccant. If discolored (deep yellow or brown), it may be contaminated. A heavily contaminated desiccant bed must be replaced to return dehydrator to optimum performance.

If correcting conditions in the troubleshooting check list does not remedy the problem, consult your local VAN GAS Distributor or call the VAN GAS factory in Lake City, Pennsylvania (888)-606-9303 or (814)-774-2636.

## 6.0 REPLACEMENT PARTS LIST

### DESICCANTS CERAMIC BEAD (PREBED)

DESCRIPTION	PART NO.
90 LB. CARTON	33-0281

### GASDRY PRIME(DRYING)

DESCRIPTION	PART NO.
50 LB. PAIL	33-0355
50 LB. BAG	33-0354

### GASDRY PEAK(DRYING)

DESCRIPTION	PART NO.
45 LB. PAIL	33-0328
50 LB. BAG	33-0205
400 LB. DRUM	33-0283

### GASDRY MAX (DRYING)

DESCRIPTION	PART NO.
7 LB. PAIL	33-0318
25 LB. PAIL	33-0232

### PLD 8, PLD 12, AND PLD 16 DEHYDRATOR

DESCRIPTION	PART NO.
BLIND PLATE	26-7126
HAMMER UNION NUT	26-7128
FILL COVER O-RING	26-7573

### PLD 20, PLD 24, AND PLD 36 DEHYDRATOR

DESCRIPTION	PART NO.
BLIND PLATE	26-7127
HAMMER UNION NUT	26-7129
FILL COVER O-RING	26-3640

GasDry Prime, GasDry Peak, and GasDry Max are the registered trade names of chemical drying agents specifically formulated by and for VAN GAS Single Tower Dehydrators.

**VAN GAS TECHNOLOGIES™**

2950 Mechanic Street  
Lake City, Pa 16423 USA  
Phone: 800-840-9906  
Fax: 814-774-0778  
www.vangastech.com